

Servo leveler "S" Loop and Active type Uncoiler

伺服整平機及主動式料架系統

Featuring High speed, Precision, Safety, and Durability.

FAIR OAKS new second-generation peripheral equipment, suitable for material thickness 0.2~0.5 mm Silicon steel sheet, it is your best choice of manufacturing EV and HEV motor.

高將新開發二代周邊系統，適合沖壓材料厚度 0.2~0.5 mm 矽鋼片，是您生產新能源電機的最佳選擇。

FSV/FST Series



高將精機廠股份有限公司
FAIR OAKS PRECISION MACHINERY(F) CO., LTD

台灣 42953 台中市神岡區溪頭路 171 號

No.171, Xitou Rd., Shengang Dist., Taichung City 42953, Taiwan

TEL: +886-4-2563 2320

FAX: +886-4-2563 3133

URL: www.fairoaks-press.com.tw

E-mail: goal.jump@msa.hinet.net



Dimensions 外觀尺寸 (450 Series 系列)

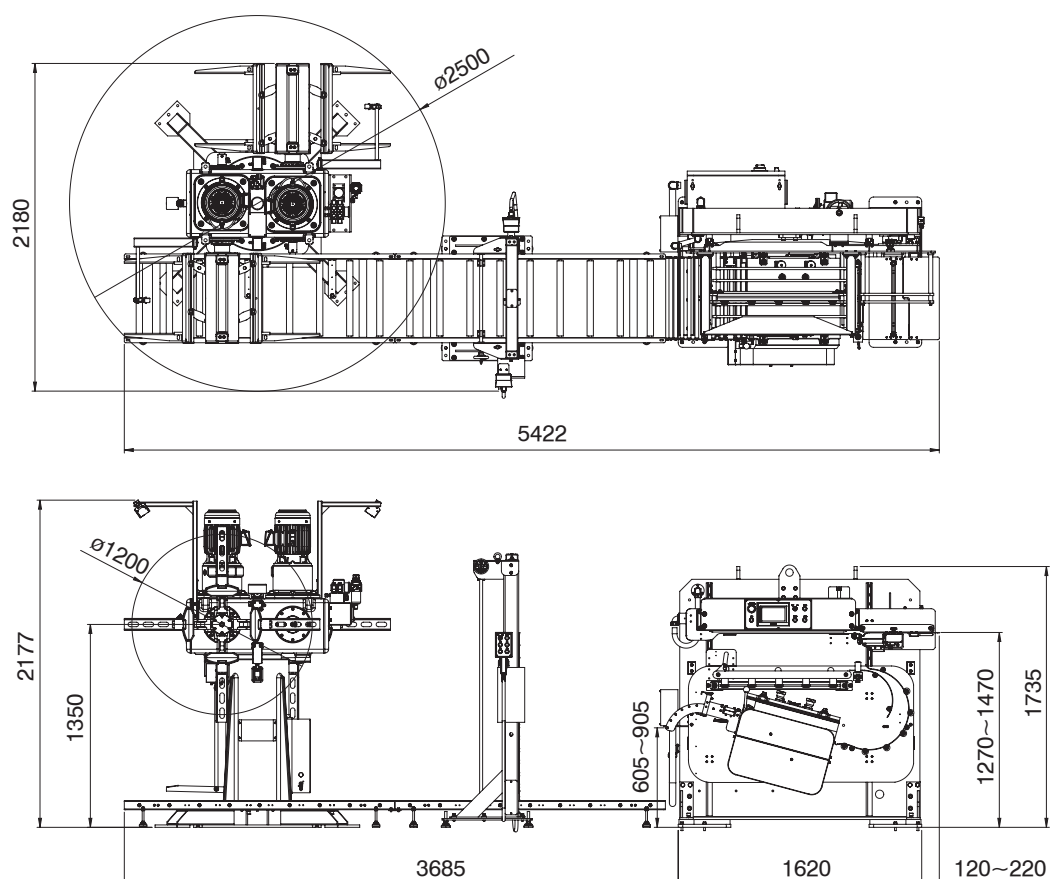

FST-450•650 SERVO LEVELER "S" LOOP 伺服整平機

MODEL	機型	單位	FST-450	FST-650
Width of material	送料寬度範圍	mm	100~450	100~650
Linear height	送料高度範圍	mm	1270~1470	1250~1450
Thickness of material	材料厚度	mm	0.2~1.0	0.2~0.5
Feed speed of leveller	料線速度	m/min	8~90	
Driving motor	矯直機拉料馬達	kw	2	

FSV-450•650 ACTIVE TYPE UNCOILER 主動式料架

MODEL	機型	單位	FSV-450	FSV-650
Max coil width	料捲最大寬度	mm	100~450	100~650
Max coil weight	料捲最大荷重	kg	3300 x 2	5000 x 2
Thickness of material	材料厚度	mm	0.2~1.0	0.2~0.5
Head rotation way	頭部料架旋轉方式		Manual 手動	Motor-driven 電動
Max coil O.D.	料捲最大外徑	mm	1200	
Expansion range (Min. / Max.)	擴張範圍	mm	450~520	
Variation range way	擴張方式		Hydraulic expansion 油壓擴張	

- If the maximum outer diameter and width of the coil, thickness of the coil material required by the actual demand exceed the specified specifications, please contact us, and we can specially design for you according to the demand.
- 如實際需求之捲料最大外徑，材料寬度及材料厚度超出表訂規範，請與本廠聯繫，本廠可依需求配合特製。
- Specifications and design characteristics are subject to change without prior notice.
- 本公司對產品規格，設計特性均不斷研究改進，上述規格若有變更，恕不另行通知。